



Paper Type: Original Article

Evaluation of Different Methods of Seismic Improvement of Structures for the Best Performance Against Progressive Failure

Reza Sedaghat^{1*}, Tahereh Bonyad Sikaroudi²

¹ Department of Civil Engineering, Tonekabon Branch, Islamic Azad University, Tonekabon, Iran; r.sedaghat69@gmail.com.

² Department of Civil Engineering, Ayandegan Institute of Higher Education, Tonekabon, Iran; tahere.sigarodi@gmail.com.

Citation:

Received: 05 January 2025

Revised: 17 February 2025

Accepted: 10 June 2025

Sedaghat, R., & Bonyad Sikaroudi, T. (2025). Evaluation of different methods of seismic improvement of structures for the best performance against progressive failure. *Journal of civil aspects and structural engineering*, 2(3), 177-194.

Abstract

In this study, the evaluation of the reinforcement of steel flexural frames against progressive failure was addressed. For this purpose, initially, two steel buildings with lateral load-bearing systems of flexural frames, whose number of floors is 3 and 5, respectively, were analyzed and designed in accordance with the national building regulations of Iran (Sections 6 and 10 and Regulation 2800). The initial analysis was performed using Etabs software. Subsequently, the perimeter frames of the buildings under study were reinforced against progressive failure by adding wind braces. The finite element software ABAQUS was used to simulate these frames. The variables under study included the number of floors (3 and 5 floors), the position of column removal in the plan (NO removal, removal of the corner column of the frame, removal of the middle column of the frame), and the position of column removal in the floors (Removal of columns in floors 1, 2, and 3). Thus, 16 steel frames were simulated and their behavior was compared with each other by examining outputs such as stress, strain, axial force of columns, and displacement of the column removal location. In the reinforced frames studied in terms of changes in the axial force of columns adjacent to the removal location, the most critical cases are those in which the middle column of the frame is removed at the lowest floor. In such a way that the ratio of the increase in the axial force of columns around the removal location in the case of removing the middle column in the three-story frame is approximately 2.15 times higher than the values corresponding to the cases of removing the corner columns. Also, the ratio of the increase in the axial force of columns around the removal location in the case of removing the middle column in the five-story frame is approximately between 5% and 49% higher than the values corresponding to the cases of removing the corner columns. On the other hand, with the increase in the number of floors, the maximum displacement of the column removal location has decreased. In such a way that depending on the position of the column removal location, the maximum displacements corresponding to the column removal location in the 5-story frames are approximately 7 to 22% lower than the values corresponding to the 3-story frames. Therefore, it can be stated that in steel flexural frames in which the solution of adding wind braces is used as a method of strengthening against progressive damage, the greater the number of floors, the greater the effectiveness of the mentioned method in improving the performance of the structure against progressive damage.

Keywords: Progressive damage, Steel braces, Steel flexural frame, Finite element method.

1 | Introduction

Today, there are structures that require seismic retrofitting for various reasons such as changes in regulations or changes in the use of structures, etc.; In this study, the performance of these structures after retrofitting

✉ Corresponding Author: r.sedaghat69@gmail.com

doi: 10.48314/jcase.vi.58



Licensee System Analytics. This article is an open-access article distributed under the terms and conditions of the Creative Commons Attribution (CC BY) license (<http://creativecommons.org/licenses/by/4.0>).

against progressive damage will be examined. So that we can analyze and examine the effect of the retrofitting process against robustness against progressive damage Ferraioli et al. [1]. Progressive damage will generally be analyzed with finite element software, in which the sudden removal of one or more structural elements due to unforeseen factors will cause the redistribution of the load to other elements.

If this sudden application of load is not considered in the design of the structure, it will cause the destruction of the structure Gerasimidis et al. [2]. The removal of this structural member can be due to poor design or improper implementation of the structural components, in other words, the removal of one or more members will cause the destruction of the whole or a major part of the structure. Seismic improvement in structures is carried out because the seismic resistance of the structure is less than the minimum required seismic resistance, so improvement must inevitably be carried out. The effect of improvement against progressive deterioration is also explored and examined in this project. This issue has not been considered in the articles and publications presented, and it is hoped that an effective step can be taken to improve the optimization and improvement of the performance of structures [3].

In addition, modern urban planning requires establishing a proportionate relationship between existing structures or those under construction with structures whose useful life has ended and need improvement. Because in a city complex, due to the density of structures, the destruction of one structure can also destroy the adjacent structure and take it out of operation, or cause significant human or financial losses to the city and society. Given that large cities are expanding at a very high speed and tall structures with high floors must be located next to unsafe structures due to lack of sufficient land.

Therefore, special attention should be paid to improving such structures and not destroying them due to reasons such as progressive deterioration. In addition, it should be considered that by improving and spending a small amount of money compared to the construction of a building, conditions will be created that will preserve the material and spiritual resources of the society [4].

In the event of an earthquake or unwanted explosions, it is possible that the structures will not be able to withstand the dead weight load or the lateral load of the earthquake due to progressive deterioration resulting from the destruction of columns or other structural components, and the structure will face total destruction. In structures that are of great importance, whether in terms of security and law enforcement or in terms of health and treatment, these damages are not acceptable under any circumstances. Because the safety and health of the affected people is the most important concern facing engineers, measures must be devised to prevent these failures in these structures [5].

Considering that the issue of progressive failure has not been raised for more than a few decades, it is expected that the integration of seismic retrofitting and progressive failure methods and the investigation of a suitable method for retrofitting against progressive failure will be an effective step in advancing new studies in this field.

2 | Methodology

2.1 | ABAQUS Software

ABAQUS software is one of the most powerful computer-aided engineering software in the field of finite element analysis on the market. The name and logo of this software are taken from the word abacus in English, meaning abacus, and abax in Greek, meaning a board covered with sand. This software is a product of the French company Dassault Systèmes. ABAQUS has the ability to solve problems from a simple linear analysis to the most complex nonlinear modeling. This software has a very extensive set of elements that can be used to model any type of geometry. It also has many behavioral models that enable high capabilities in modeling a variety of materials with different properties and behaviors, such as metals, rubbers, polymers, composites, reinforced concrete, springy and brittle foams, as well as geotechnical materials such as soil and rock. Since ABAQUS is a general and extensive modeling tool, its use is not limited to the analysis of solid mechanics problems (i.e., the stress-strain problem). Using this software, various problems such as heat

transfer, mass diffusion, thermal analysis of electrical, acoustic, seepage, and piezoelectric components can be studied. Despite the extensive set of capabilities available to the user in using the software, ABAQUS is relatively simple to use. The most complex problems can be easily modeled.

For example, problems involving more than one component can be modeled by creating a geometric model of each component, then assigning the corresponding material behavior to each component, and then assembling the various components. In most modeling, even models with a high degree of nonlinearity, the user only needs to specify engineering data such as the geometry of the problem, the material behavior of the component, the boundary conditions, and the loading of the problem.

In a nonlinear analysis, ABAQUS automatically selects the load growth rate and convergence tolerances and adjusts them during the analysis to achieve the correct solution. As a result, the user rarely has to specify the values of the control parameters of the numerical solution of the problem. The main idea of the software was presented in Carstensen [6] in 2009, entitled "computational mechanics based on the finite element method" at Applied numerical mathematics.

In 1995, Mr. Hebit [7], along with his two partners Carlson and Sorenson, founded HKS and released the first edition of ABAQUS. In 1991, HKS added the ABAQUS/Explicit solver to the software suite and released its main software. Finally, in 1999, the first graphical version was released as ABAQUS/CAE. The first graphical version of ABAQUS was 9 modules for modeling, solving, and extracting results.

Abaqus/CAE includes an environment for designing and modeling (Preprocessing) and graphically displaying the results of the analysis. ABAQUS software consists of 3 parts:

- I. Abaqus/standard, which is a general finite element method-based analyzer that uses an implicit integration approach.
- II. Abaqus/explicit, which is a specific finite element analyzer that uses an explicit integration approach and is used to solve nonlinear systems including contact problems and in transient loading conditions.
- III. Abaqus/CFD, which is a fluid dynamics analysis software. This software also supports the open source Python programming language for programming within the software. The ability to write scripts within the software doubles its modeling capabilities. One of the most important features of ABAQUS software compared to other existing finite element software is the ability to change and add to the software's features and libraries.

A feature called "Subroutine" writing is a very powerful tool for professional users. A subroutine is actually a set of code written by the user using the Fortran programming language for a specific application. Using this feature, you can do things like define new behavior models, perform specific loadings, and so on.

2.2 | Validation of Composite Frame

In this section, the validation of the finite element method used is carried out using numerical simulation of a single-story, single-span composite roof flexural frame. In the following, first, the necessary explanations about the laboratory study conducted by Lan Hui Gu et al [8]. in 2013 and its validation was examined in the present study will be provided, and then the details related to the finite element modeling used will be explained.

2.3 | Geometrical Specifications and Materials Used in the Study

As mentioned, the frame under study has one story and four spans, which was built at a scale of 1.3 in the laboratory. The length of each frame span is 2 meters and its height is 1.20 meters. The steel beams are fully welded to the column flanges so that the connections between the beam and the column are rigid (Reinforced). The cross-section of the beams is H200×100×5.5×8 and the cross-section of the columns is H200×200×8×12. (The numbers after H are: D: Overall height of the section; bf: Flange width; tw: Web thickness; tf: Flange thickness, respectively) [8].

The depth and width of the slabs are 100 and 80 mm, respectively. The percentage of steel in the reinforcing mesh is also considered to be 0.85%. Longitudinal reinforcing bars with a diameter of 12 mm are placed in two layers with equal intervals along the width of the slab. Also, transverse bars with a diameter of 8 mm are used in the reinforcement mesh to prevent concrete failure and in the direction perpendicular to the longitudinal bars. In order to simulate the removal of the column, the middle column is not supported (Fig. 1).

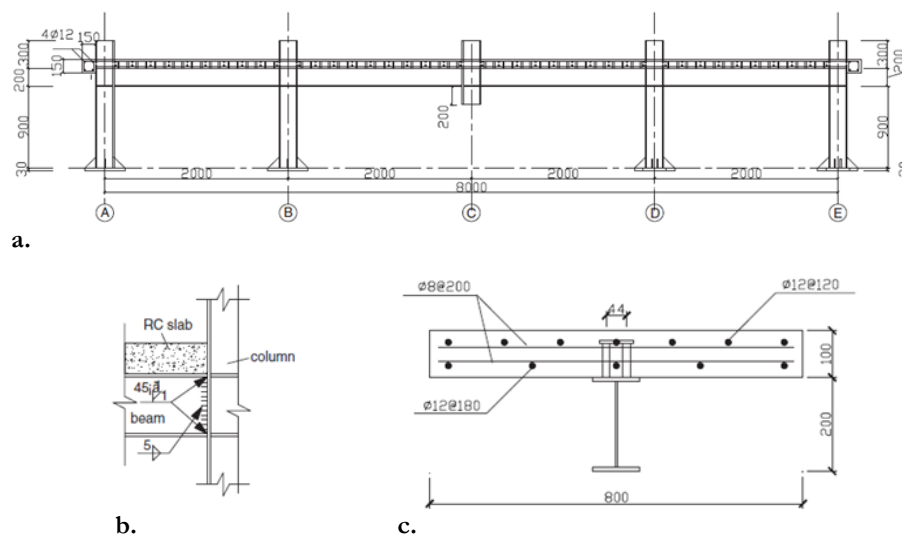

Fig. 1. Frame details and dimensions; a. detail dimension of frame (mm), b. full-welded beam-to-column connection, and c. cross section composite beam.

Fig. 1 shows the image of the beam after concreting. The material specifications are shown in Table 1. In Table 1, f_y , f_u E_s are the yield stress, ultimate stress and modulus of elasticity, respectively. The average compressive strength of the concrete cube specimens used is 26.64 MPa. The modulus of elasticity of the concrete is 26500 MPa.



Fig. 2. Image of the beam after concreting.

Table 1. Specifications of Lan Hui Guo et al. [8] frame materials.

Se.		f_y (MPa)	f_u (MPa)	E_s (10^5 MPa)
Beam	Flange	269	401	1.96
	Web	275	411	2.09
Column	Flange	247	396	2.00
	Web	276	415	1.98
Reinforcement	Φ8	325	487	-
	Φ12	331	464	1.95

The frame test equipment under investigation is shown in Fig. 3. To provide a fixed support (Girder), the foot of the columns was welded to a beam attached to the ground.



Fig. 3. The laboratory frame under investigation along with the equipment used.

The behavior of the frame and the concrete slab on it was evaluated and measured during the test. For this purpose, a linear displacement measuring device (Displacement transducer or LVDT) was placed vertically in the middle of the frame and at the location of column C.

Also, four displacement transducers were used horizontally to measure the horizontal displacement of columns A, B, D and E. The location of the displacement transducers is shown in *Fig. 4*.

For loading, a hydraulic jack with a loading capacity of 500 kN was used on top of column C to create a continuous vertical load.

Also, a 1000 kN loading device was used to accurately measure the vertical load. Using this method and the devices mentioned, it is easy to examine the redistribution and transfer of internal force after removing the middle column of the frame.

The applied load was applied according to the JGJ 101-96 regulations of China. In the elastic range, the vertical load was applied with an incremental step of 1.5 (One fifth) of the load-bearing capacity of the samples.

After the frame reached the yield point, the load-displacement control method was used until the frame reached its final capacity.

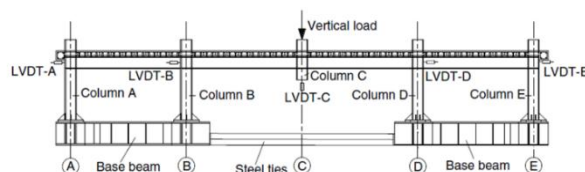

Fig. 4. Distribution of displacement gauges in different parts of the frame.

The following *Figs. 5-10* show images of the frame after the test.



Fig. 5. General view of the tested steel frame after loading.



Fig. 6. Curvature created in columns A and B.



Fig. 7. Beam buckling inside connection B.



Fig. 8. Cracks in the slab in the middle connection area.



Fig. 9. Buckling of slab rebar.



Fig. 10. Cracks in the slab at connection area B.

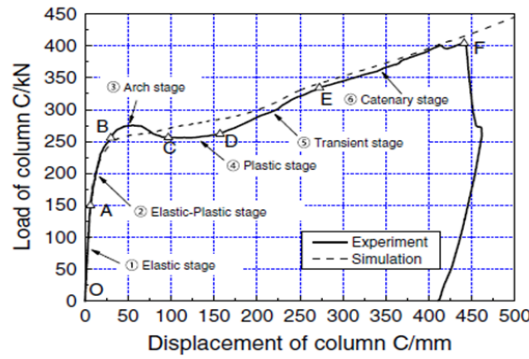

Fig. 11. Load-displacement relationship curve of the middle column in the laboratory and the numerical model of Lan Hui Gu et al [8].

3 | Findings

3.1 | Evaluation of the Results of the Analysis

After modeling and analyzing the buildings under study, the results obtained in the form of diagrams of strain distribution, axial force of columns, stress distribution, displacement of the column removal location and the changed shape of the structure are presented separately in this section for each of the 3- and 5-story models and will be analyzed at the end.

3.2 | First Case (Three-Story Building in the State Without Reinforcement, without Removal)

Fig. 12 shows the strain distribution, axial force of the column foot, stress distribution and changed shape of the structure for the 3-story medium-sized bending frame in the state without column removal and without reinforcement, respectively. As can be seen, the maximum strain is 0.00251, the maximum axial force is 19.57 kN and the maximum stress is 75.65 MPa.

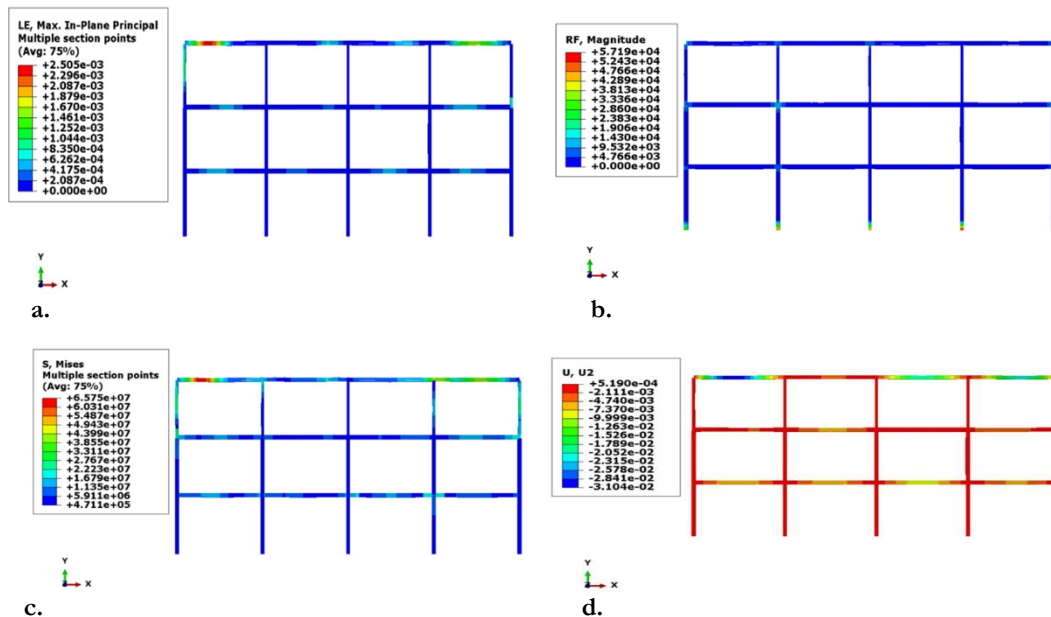

Fig. 12. Outputs from the analysis in the first case; b. Column axial force, c. Tension, and d. Tension.

3.3 | Case 2 (Three-Story Building, Reinforced by Adding Wind Braces, without Removing Columns)

Fig. 13 presents the results of the analysis of a three-story steel frame reinforced by adding wind braces, without removing columns. As can be seen, the maximum strain is 0.00214, the maximum axial force is 108.3 kN, and the maximum stress is 56.26 MPa.

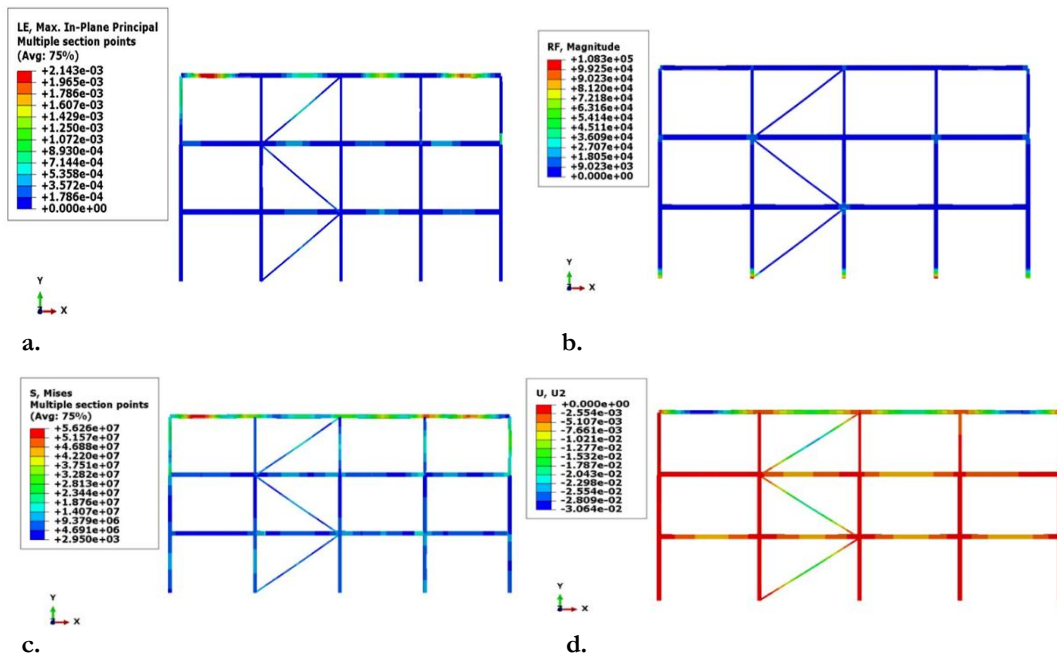
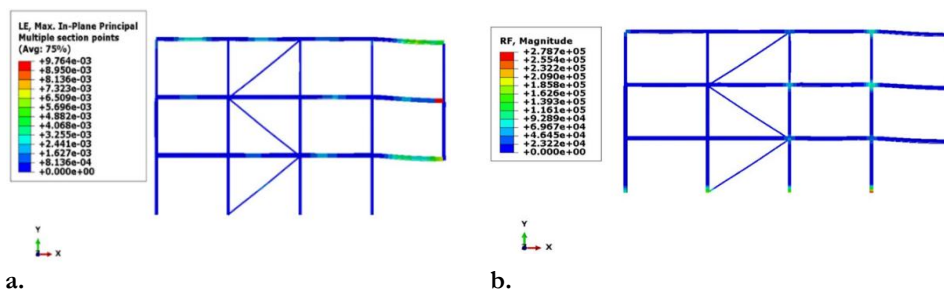

Fig. 13. Outputs from the analysis in the second case; b. Column axial force, c. Tension, and d. Tension.

3.4 | Case 3 (Three-Story Building in the Retrofitted State-Side Column Removed on the 1st Floor)

Fig. 14 shows the results of the analysis of the three-story retrofitted frame with the side column removed on the first floor. As can be seen, the maximum strain is 0.00976, the maximum axial force is 278.7 kN, the maximum stress is 197.10 MPa, and the maximum displacement at the location of the column removal in this case is 570 mm.



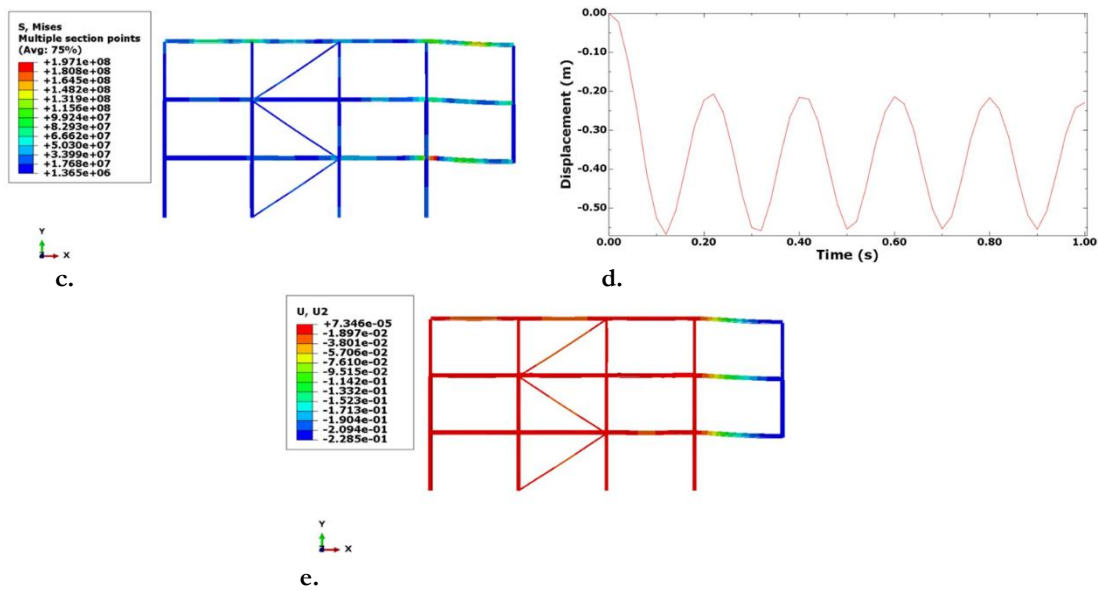
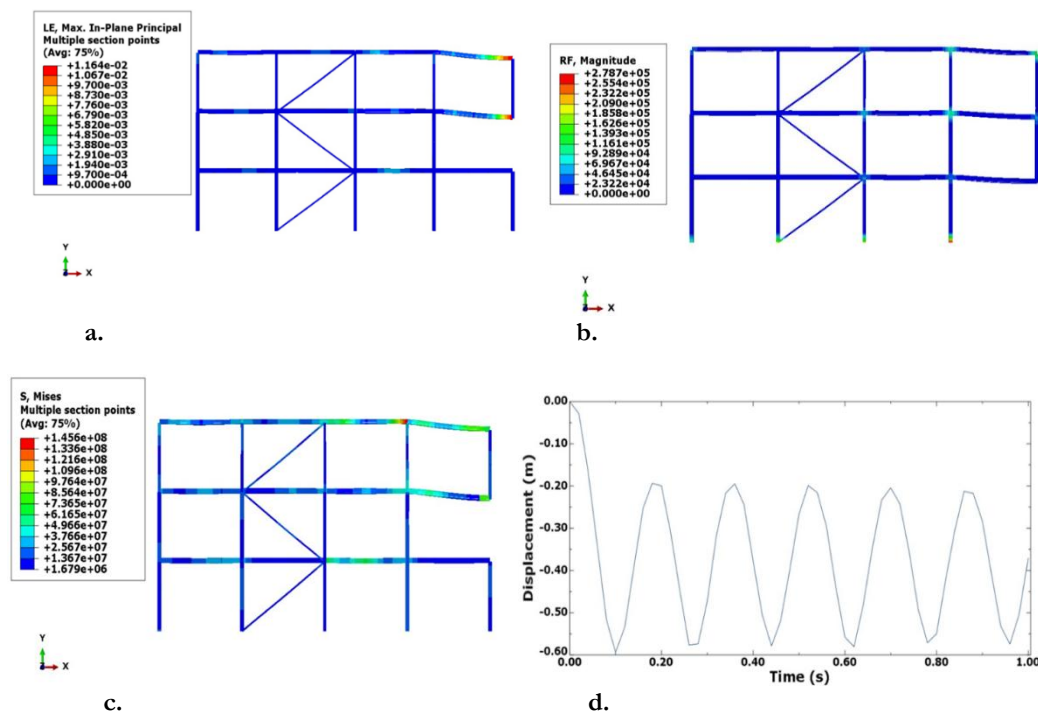
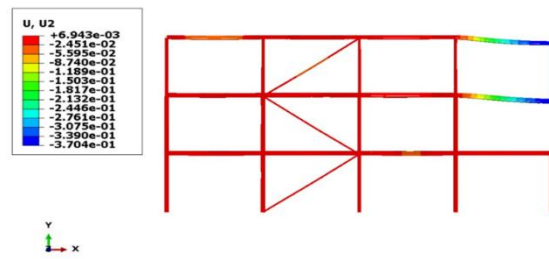

Fig. 14. Outputs from the analysis in the third case; a. Strain, b. Column axial force, c. Column axial force, d. Column removal location relocation history, and e. Modified frame shape.

3.5 | Case 4 (Three-Story Building in the Retrofitted State-Removal of the Side Column on the 2nd Floor)

Fig. 15 shows the results of the analysis of the three-story retrofitted frame with the side column removed on the second floor. As can be seen, the maximum strain is 0.01164, the maximum axial force is 244.9 kN, the maximum stress is 145.6 MPa, and the maximum displacement at the location of the column removal in this case is 370.40 mm.





e.

Fig. 15. Outputs from the analysis in the fourth case; a. Strain, b. Column axial force, c. Tension, d. Column removal location relocation history, and e. Modified frame shape.

3.6 | Fifth Case (Three-Story Building in the Retrofitted State-Removal of the Side Column on the 3rd Floor)

Fig. 16 shows the results of the analysis of the three-story retrofitted frame with the side column removed on the third floor. As can be seen, the maximum strain is 0.00810, the maximum axial force is 218.20 kN, the maximum stress is 106.60 MPa, and the maximum displacement at the location of the column removal in this case is 440.70 mm.

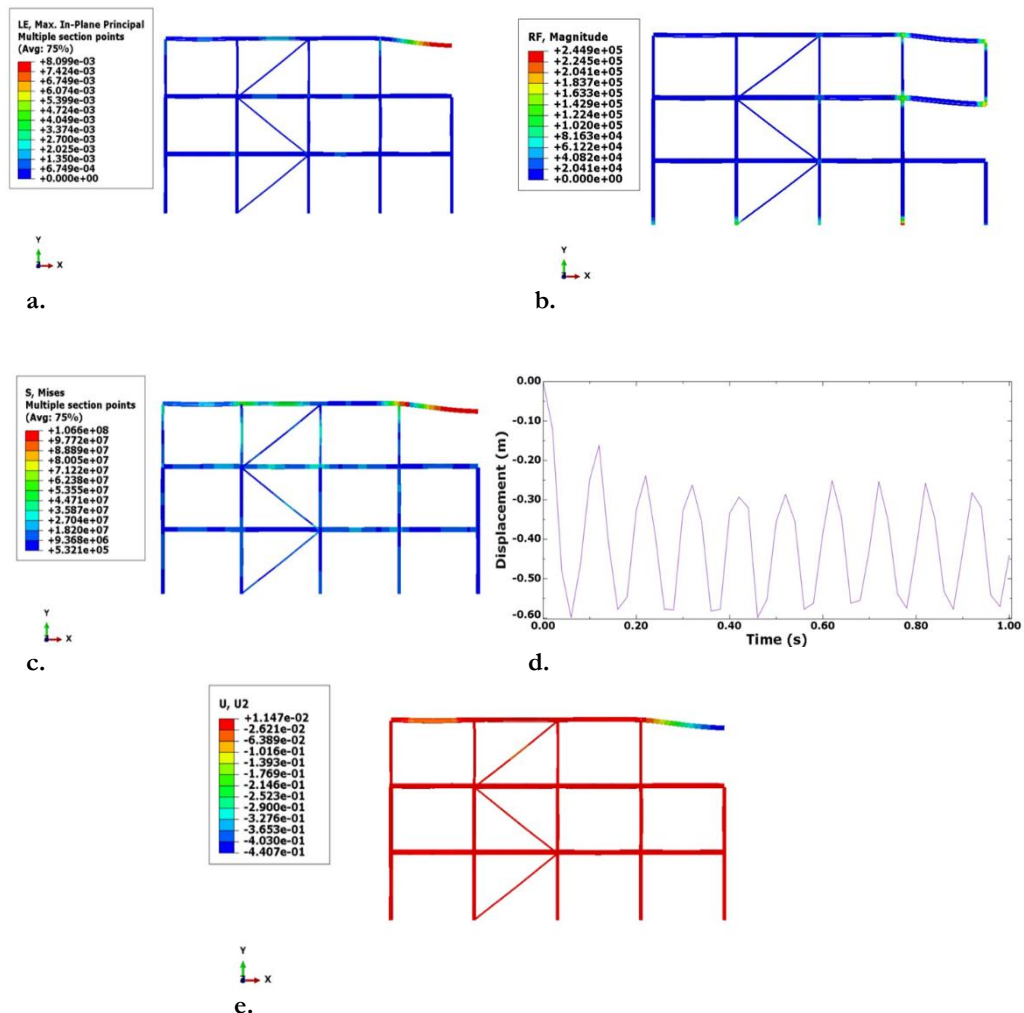

Fig. 16. Outputs from the analysis in the fifth case; a. Strain, b. Column axial force, c. Tension, d. Column removal location relocation history, and e. Modified frame shape.

3.7 | Case 6 (Three-Story Building in the Retrofitted State-Removal of The Middle Column on the First Floor)

Fig. 17 The outputs from the analysis of the three-story retrofitted frame with the middle column on the first floor removed are shown. As can be seen, the maximum strain is 0.02207, the maximum axial force is 3.558 kN, the maximum stress is 8.275 MPa, and the maximum displacement of the column removal location in this case is 575 mm.

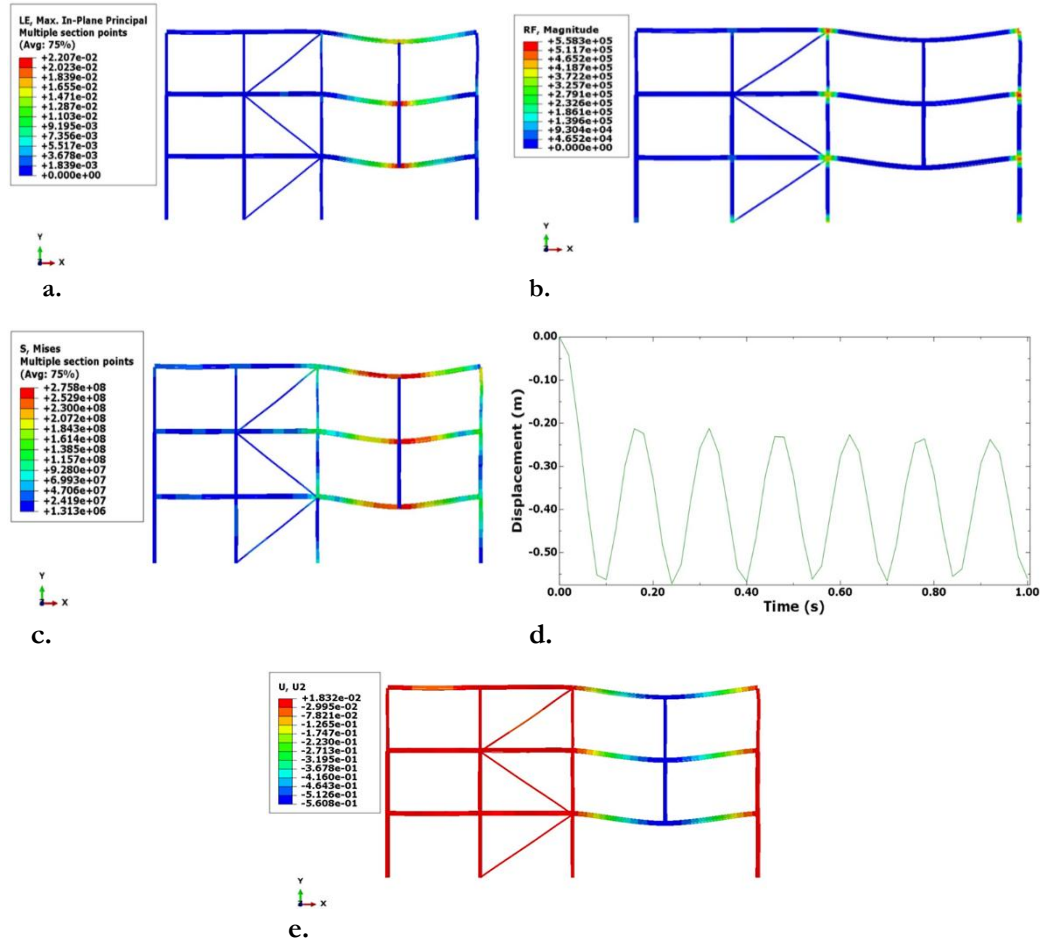

Fig. 17. Outputs from the analysis in the sixth state; a. Strain, b. Column axial force, c. Tension, and e. Modified frame shape.

3.8 | Seventh Case (Three-Story Building in the Retrofitted State-Removal of the Middle Column on the 2nd Floor)

Fig. 18 shows the results of the analysis of the three-story retrofitted frame with the middle column removed on the second floor. As can be seen, the maximum strain is 0.01861, the maximum axial force is 344 kN, the maximum stress is 197.8 MPa, and the maximum displacement of the column removal location in this case is 610 mm.

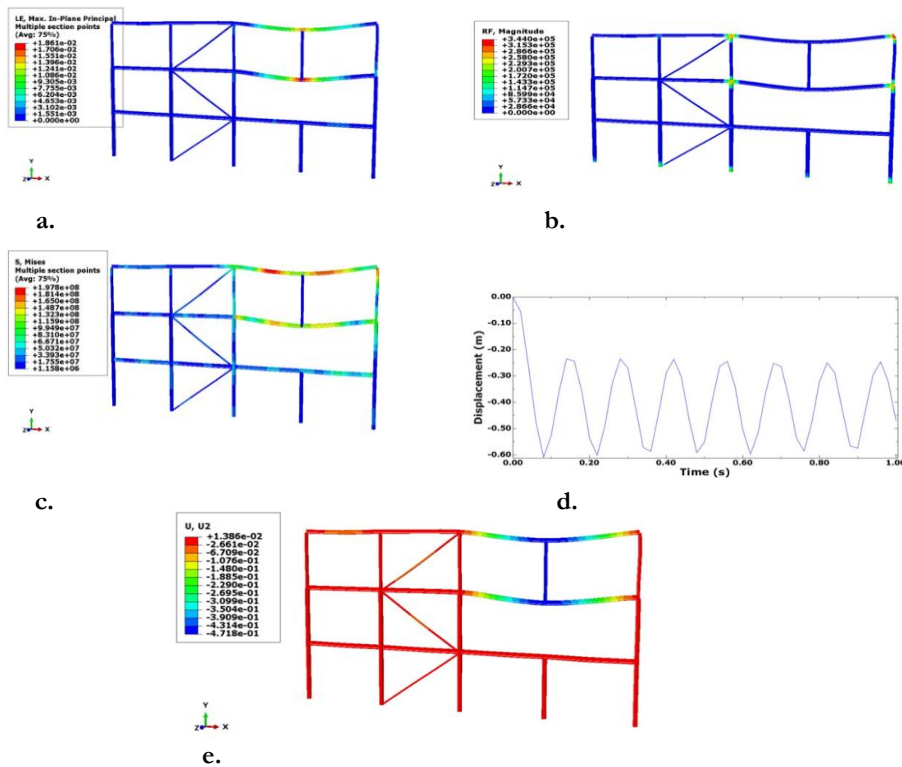
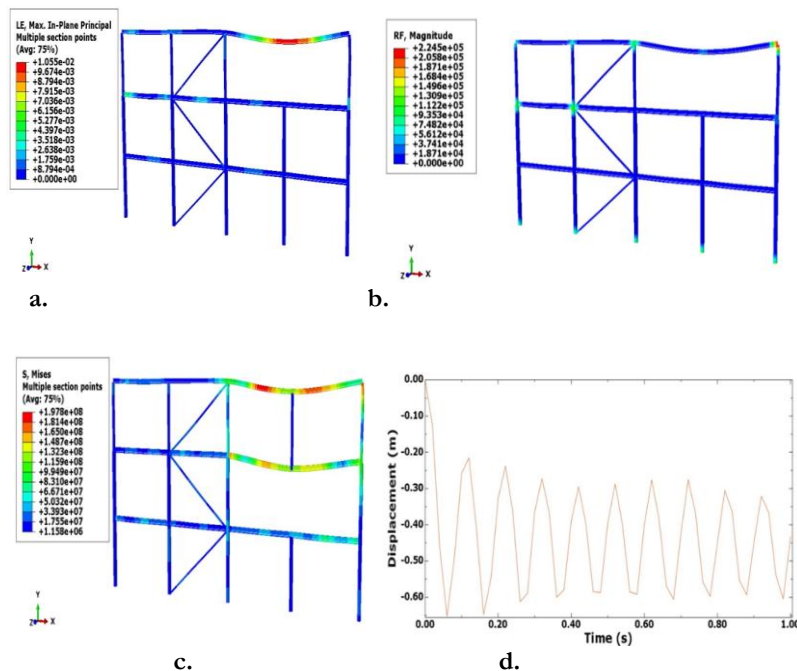

Fig. 18. Outputs from the analysis in the seventh state; a. Strain, b. Column axial force, c. Tension, d. Column removal location relocation history, and e. Modified frame shape.

3.9 | Case 8 (Three-Story Building in the Retrofitted State-Removal of the Middle Column on the 3rd Floor)

Fig. 19 shows the results of the analysis of the three-story retrofitted frame with the middle column removed on the third floor. As can be seen, the maximum strain is 0.01055, the maximum axial force is 224.5 kN, the maximum stress is 144.6 MPa, and the maximum displacement at the location of the column removal in this case is 659 mm.



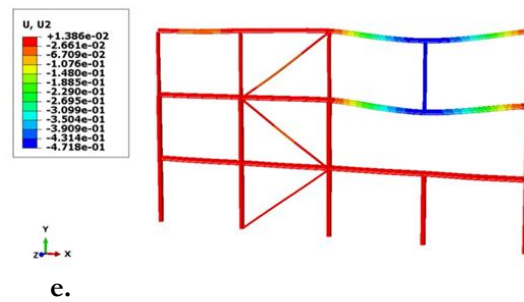

Fig. 19. Outputs from the analysis in the eighth state; a. Strain, b. Column axial force, c. Tension, d. Column removal location relocation history, and e. Modified frame shape.

After presenting the results of the analysis of the steel frames under study in 8 different cases, this section deals with the interpretation of the results. As can be seen, in the present study, the strengthening of steel flexural frames against progressive failure by adding braces has been evaluated. In *Table 2*, the maximum stress values, the maximum axial force at the column foot, and the maximum strain generated in the frames in the four cases in which the column has not been removed have been compared with each other.

Table 2. Comparison of results of retrofitted frames compared to non-retrofitted frames.

Mode	Frame Type	Stress (MPa)	Strain	Column Foot Axial Force (kN)
1	3-story torsional frame without column removal	65.75	0.00205	57.19
2	3-story torsional frame reinforced with wind braces without column removal	56.26	0.00214	108.30
9	5-story torsional frame reinforced with wind braces without column removal	56.12	0.00167	485.70
10	Frame type	60.36	0.00167	412.80

According to *Table 2*, it can be seen that adding bracing to 3-story flexural frames against gravity loads has resulted in a 14% reduction in strain and stress; but it has increased the maximum axial force at the column foot by about two times. However, with increasing height, the results are different; so that in the 5-story frame, with the addition of bracing, no significant change in stresses and strains has been observed, and the axial force at the column foot has also decreased by about 15%.

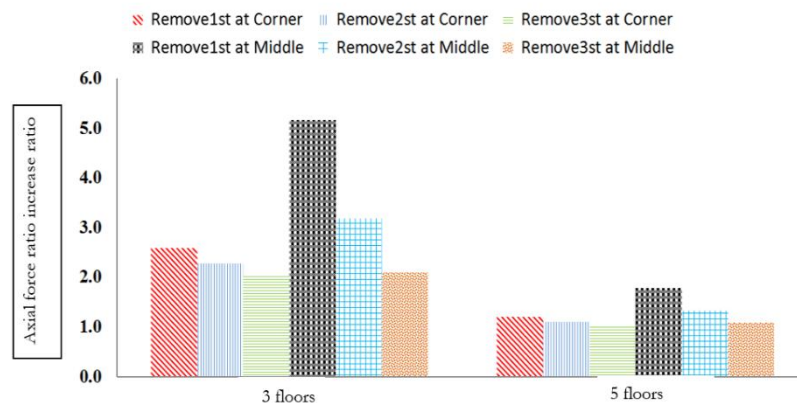

Fig. 20. Comparison of the ratio of increase in maximum axial force at the foot of columns around the removal site.

One of the most important parameters examined in studies related to progressive failure is the redistribution of axial forces of columns around the removal site. In other words, the changes in the axial force of columns located in the vicinity of the removal site compared to the corresponding state before removal is a criterion for measuring the behavior of the structure against progressive failure. In the present study, the ratio of the maximum axial force of columns adjacent to the removal site compared to the values corresponding to the

state without removal was calculated for 12 cases in which the column was removed at different positions and compared with each other in the column chart of *Fig. 21*. As can be seen, in the strengthened frames studied in terms of changes in the axial force of columns adjacent to the removal site, the most critical cases are those in which the middle column of the frame is removed at the lowest floor.

So that the ratio of the increase in the axial force of columns around the removal site in the case of removing the middle column in a three-story frame is approximately 15.2 times higher than the values corresponding to the cases in which the corner columns are removed. Also, the ratio of the increase in the axial force of the columns around the removal location in the case of removing the middle column in the five-story frame is approximately between 5% and 49% of the values corresponding to the cases of removing the corner columns. Therefore, in the strengthening of steel flexural frames using braces, due to the more critical case of removing the middle columns compared to removing the corner columns, more attention should be paid to the middle columns and the changes in the axial force in them. The changes mentioned above can also be seen in *Figs. 22* and *23*.

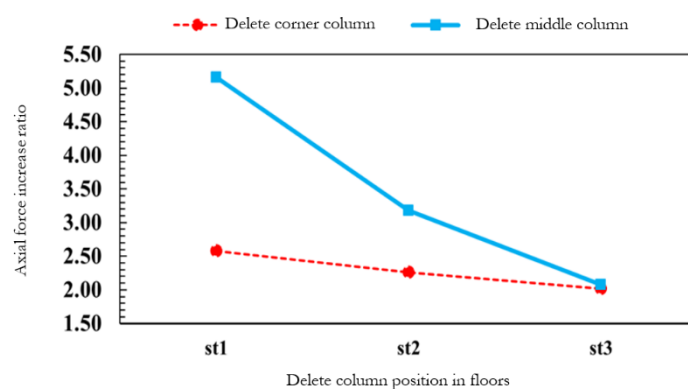

Fig. 21. Ratio of increase in axial force of columns around the removal location with the aim of examining the position of column removal in the plan and floors (3-story frame).

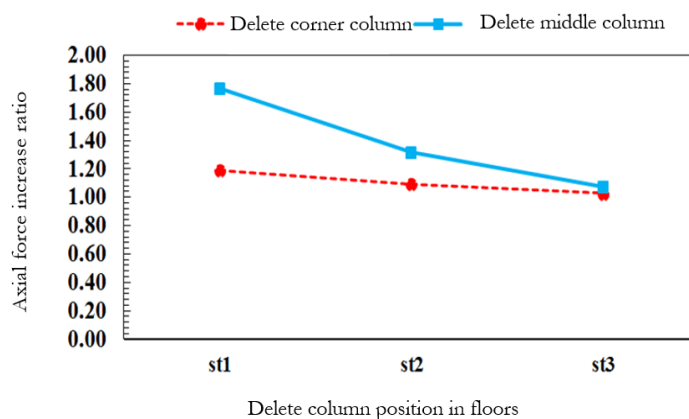

Fig. 22. Ratio of increase in axial force of columns around the removal location with the aim of examining the position of column removal in the plan and floors (5-story frame).

On the other hand, according to *Fig. 22*, the ratio of the increase in the axial force of the columns adjacent to the removal location in the case of column removal on the lowest floor of the three-story frame, depending on the location of the removal location in the plan, has increased by approximately 1.27 to 2.4 times the values corresponding to the column removal locations on the highest floor.

Also, according to *Fig. 23*, the ratio of the increase in the axial force of the columns adjacent to the removal location in the case of column removal on the lowest floor of the five-story frame, depending on the location

of the removal location in the plan, has increased by approximately 15% to 64% of the values corresponding to the column removal locations on the highest floor.

In other words, when the column is removed on the first floor, the axial force changes are greater than the values corresponding to the column removal locations on the second and third floors. The reason for this is that when the column is removed on the lower floors, due to the greater gravity load, the behavior of the structure becomes more critical against column removal.

It is important to note that studies conducted in the field of progressive collapse show that removing columns in the lowest floors can create a more critical state for the building such a result was also obtained in the present study, according to *Figs. 21-23* [4], [9], [10].

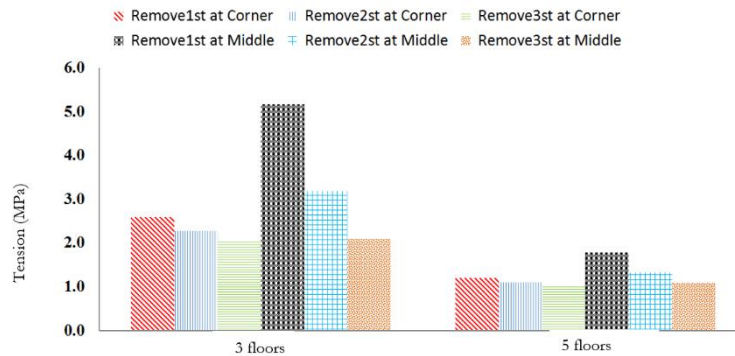

Fig. 23. Comparison of maximum stresses created in the steel frames under study.

According to *Fig. 21*, it is observed that the ratio of the axial force changes of the columns in the 3-story reinforced steel frame in the highest and lowest cases is 2.01 and 5.16, respectively. Also, the ratio of the axial force changes of the columns in the 5-story reinforced steel frame in the highest and lowest cases is 1.32 and 1.03, respectively.

According to the obtained ratios, it can be stated that with an increase in the number of floors, the axial force ratios of the columns in the removed location decrease. This issue has been repeated for both the corner and middle column removal cases. Therefore, it can be concluded that in steel frames reinforced with steel braces, increasing the height of the building reduces the probability of progressive failure.

The reason for this is that with the increase in the number of floors, more structural members contribute to the load-bearing capacity of the structure and can contribute in a chain to the load-bearing capacity of the structure in the absence of a load-bearing structural member, thus preventing the progress of failure.

Fig. 24 compares the maximum stresses created in the steel frames under study. As can be seen, in both 3- and 5-story frames, when the column in the middle of the frame is removed, the maximum stresses created in the strengthened steel frames under study are much higher than in cases in which the column in the corner of the frame is removed. Thus, the maximum stresses created in the three-story frames whose middle column is removed are 35% to 39% higher than the values corresponding to the removal of the corner column.

Also, the maximum stresses generated in five-story frames with the middle column removed are 2% to 93% higher than the values corresponding to the removal of the corner column. On the other hand, according to Fig. 24, it is observed that in most of the cases studied, the removal of the column at the lower stories leads to more critical responses in terms of stress.

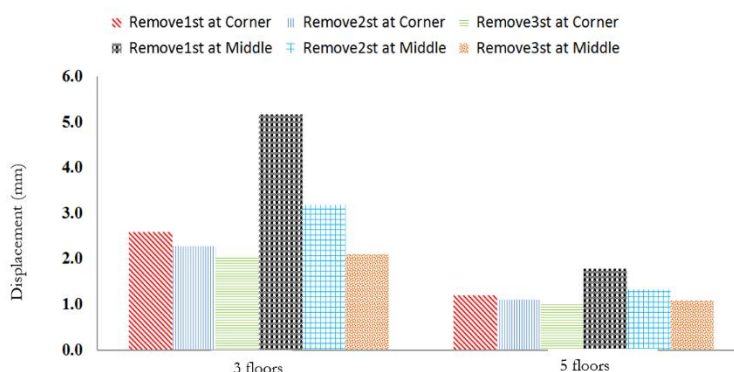

Fig. 24. Maximum displacement at the location of column removal in reinforced steel flexural frames.

The maximum displacement of the column removal location in the reinforced steel flexural frames has been compared with each other. As can be seen, the maximum displacement of the column removal location has decreased with increasing number of floors. Depending on the location of the column removal location, the maximum displacements corresponding to the column removal mode in the 5-story frames have decreased by approximately 7% to 22% of the values corresponding to the 3-story frames.

Therefore, it can be stated that in the steel flexural frames in which the wind brace addition solution is used as a method of strengthening against progressive damage, the greater the number of floors, the greater the effectiveness of the mentioned method in improving the performance of the structure against progressive damage.

4 | Conclusion

The results of this study indicate that the use of wind braces as a strengthening strategy significantly influences the structural response of steel flexural frames against progressive failure, with different effects observed depending on the number of stories. While adding braces reduces stresses and strains in three-story frames and alters the axial force distribution in columns, the behavior of five-story frames shows a different trend, highlighting the role of structural height in progressive failure resistance. Moreover, the analyses reveal that the removal of middle columns, particularly at lower floors, leads to more critical conditions compared to corner column removal, emphasizing the need for special attention to these elements; the remaining findings are presented in the following points.

- I. In the strengthened frames under study, in terms of changes in the axial force of the columns adjacent to the removal location, the most critical cases are those in which the middle column of the frame is removed at the lowest floor. So that the ratio of the increase in the axial force of the columns around the removal location in the case of removing the middle column in the three-story frame is about 15.2 times higher than the values corresponding to the cases of removing the corner columns.
- II. Also, the ratio of the increase in the axial force of the columns around the removal location in the case of removing the middle column in the five-story frame has increased by approximately 5% to 49% of the values corresponding to the cases of removing the corner columns.
- III. The ratio of the increase in the axial force of the columns adjacent to the removal location in the case of removing the column on the lowest floor of the three-story frame, depending on the position of the removal location in the plan, has increased by approximately 1.27 to 2.4 times the values corresponding to the cases of removing the column on the highest floor.

- IV. The ratio of the increase in the axial force of the columns adjacent to the removal location in the case of column removal on the lowest floor of the five-story frame, depending on the location of the removal location in the plan, has increased by approximately 15% to 64% of the values corresponding to the column removal cases on the highest floor. In other words, when the column is removed on the first floor, the axial force changes are greater than the values corresponding to the column removal cases on the second and third floors. The reason for this is that when the column is removed on the lower floors, due to the greater gravity, the behavior of the structure against column removal becomes more critical.
- V. The ratio of the axial force changes of the columns in the 3-story reinforced steel frame in the highest and lowest cases is 2.01 and 5.16, respectively. Also, the ratio of the axial force changes of the columns in the 5-story reinforced steel frame in the highest and lowest cases is 1.32 and 1.03, respectively. According to the obtained ratios, it can be stated that with increasing the number of floors, the axial force ratios of the columns at the location of the removal decrease. This issue has been repeated for both corner and middle column removal cases. Therefore, it can be concluded that in steel frames strengthened with steel braces, increasing the height of the building reduces the probability of progressive failure. The reason for this is that with increasing the number of floors, more structural members contribute to bearing the applied loads and can contribute in a chain to the load-bearing of the structure in the absence of a load-bearing structural member, thus preventing the progress of failure.
- VI. In both 3- and 5-story frames, when the column in the middle of the frame is removed, the maximum stresses created in the strengthened steel frames under study are much higher than in cases in which the column at the corner of the frame is removed. The maximum stresses in three-story frames whose middle column has been removed have been 35% to 39% higher than the values corresponding to the removal of the corner column. The maximum stresses in five-story frames whose middle column has been removed have been 2% to 93% higher than the values corresponding to the removal of the corner column.
- VII. With the increase in the number of floors, the maximum displacement at the location of the column removal has decreased. Depending on the location of the column removal, the maximum displacements corresponding to the column removal in 5-story frames have been approximately 7% to 22% lower than the values corresponding to the 3-story frames. Therefore, it can be stated that in steel bending frames in which the solution of adding wind braces is used as a method of strengthening against progressive damage, the greater the number of floors, the greater the effectiveness of the mentioned method in improving the performance of the structure against progressive damage.

Funding

This research received no external funding.

Data Availability

The datasets used or analyzed during the current study are available from the corresponding author upon reasonable request.

Conflicts of Interest

The authors declare no conflict of interest.

Authors' Contributions

R. S.: Software, Visualization, Methodology, Conceptualization, Formal Analysis, and Writing-original draft.
T. B. S.: Research Design, Data Curation, Conceptualization, and Validation, and Investigation, Writing-Review and Editing, and Validation. The authors have read and agreed to the published version of the manuscript.

Consent for Publication

The authors confirm consent for the publication of this work

Ethics Approval and Consent to Participate

This article does not include experiments involving humans or animals.

Reference

- [1] Ferraioli, M., Laurenza, B., Lavino, A., & De Matteis, G. (2024). Progressive collapse analysis and retrofit of a steel-RC building considering catenary effect. *Journal of constructional steel research*, 213, 108364. <https://doi.org/10.1016/j.jcsr.2023.108364>
- [2] Gerasimidis, S., & Sideri, J. (2016). A new partial-distributed damage method for progressive collapse analysis of steel frames. *Journal of constructional steel research*, 119, 233–245. <https://doi.org/10.1016/j.jcsr.2015.12.012>
- [3] Gul, F. A., Islam, M. R., Rahman, W., & Gul, F. A. (2017). Highland towers collapsed, the tragic story of Malaysia! *International journal for research in social science and humanities*, 3(2), 10–19. <https://doi.org/10.53555/ssh.v3i2.321>
- [4] Fu, F. (2012). Response of a multi-storey steel composite building with concentric bracing under consecutive column removal scenarios. *Journal of constructional steel research*, 70, 115–126. <https://doi.org/10.1016/j.jcsr.2011.10.012>
- [5] Kokot, S., & Solomos, G. (2012). *Progressive collapse risk analysis: Literature survey, relevant construction standards and guidelines*. Ispra: Joint research centre, european commission. <https://www.academia.edu/download/82920580/lbna25625enn.pdf>
- [6] Carstensen, C. (2009). Convergence of adaptive finite element methods in computational mechanics. *Applied numerical mathematics*, 59(9), 2119–2130. <https://doi.org/10.1016/j.apnum.2008.12.006>
- [7] Hibbitt, D., Karlsson, B., & Sorensen, P. (1995). *Abaqus/CAE user's manual*. <https://classes.engineering.wustl.edu/2009/spring/mase5513/abaqus/docs/v6.6/books/usi/default.htm>
- [8] Guo, L., Gao, S., Fu, F., & Wang, Y. (2013). Experimental study and numerical analysis of progressive collapse resistance of composite frames. *Journal of constructional steel research*, 89, 236–251. <https://doi.org/10.1016/j.jcsr.2013.07.006>
- [9] Askarian, B., & Hashemi Rezvani, F. (2010). Investigation of progressive failure in braced steel frames. *Fifth national congress of civil engineering*. Mashhad, Iran. Civilica. **(In Persian)**. <https://civilica.com/doc/80678/>
- [10] Khairuddin, A., & Fallahzadeh Fini, S. (2014). Investigation of the behavior of regular and irregular steel structures due to the phenomenon of progressive deterioration. *The first national conference on the development of civil, architectural, electrical and mechanical engineering in Iran*. Gorgan, Iran. Civilica. **(In Persian)**. <https://civilica.com/doc/325873/>